

DYNAFOIL

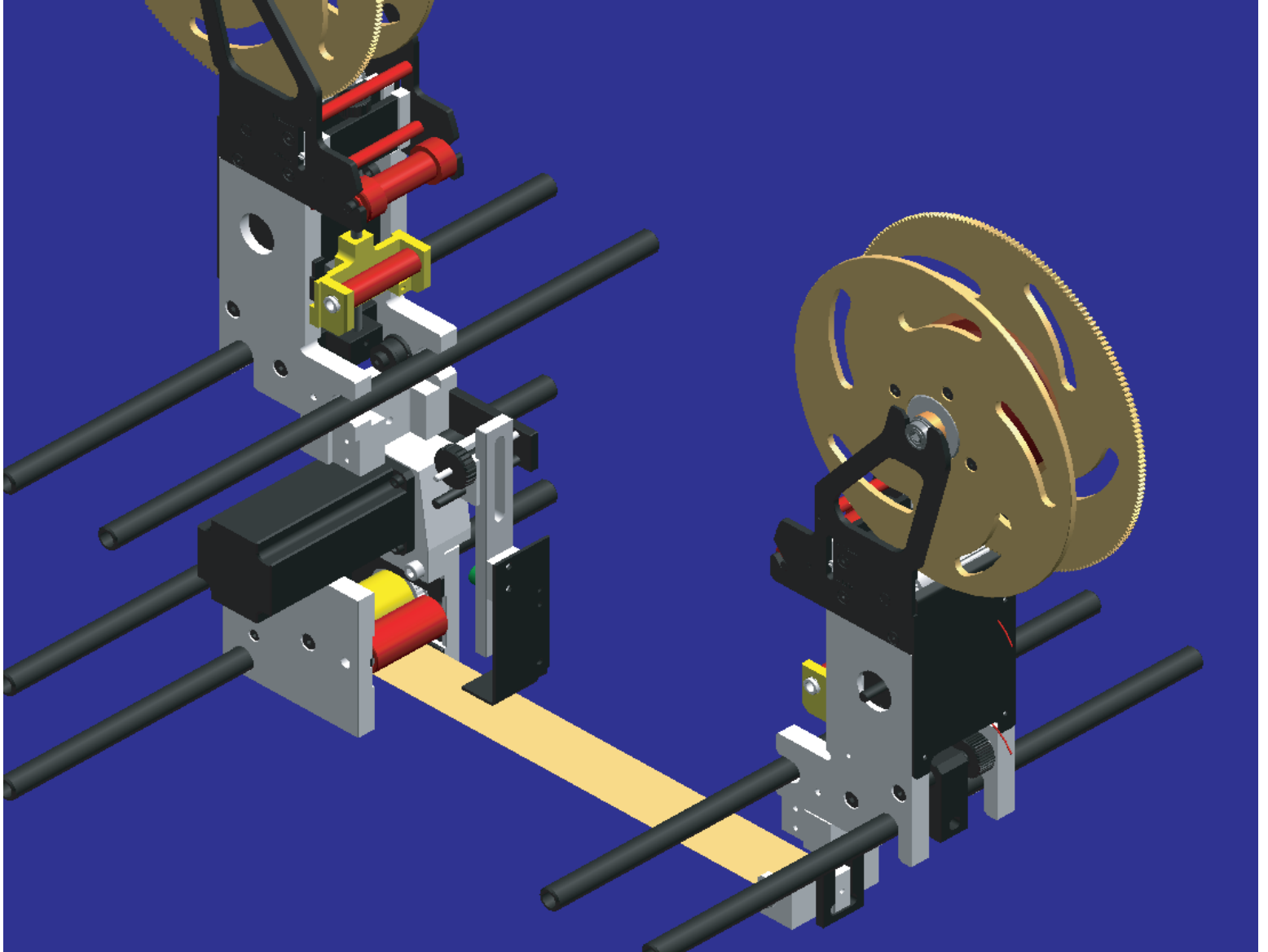

**The multi-function
foil optimization system**

DYNAFOIL : THE MULTI-FUNCTION FOIL OPTIMIZATION SYSTEM

- Registered Holograms
- Foil optimizer for Rotary Hot Foil Stamping
- Magnetic strip application
- Special Applications

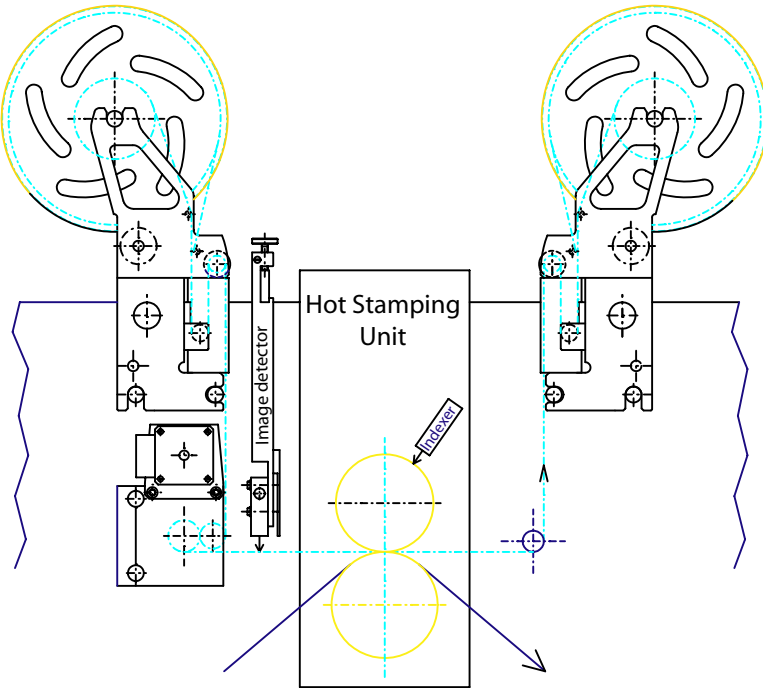

- * Multi-lanes
- * Easy to add to existing equipment
- * Independently servo-driven
- * System can be expanded to multi-lane
- * Servo: single or combination drive
- * Operator friendly - standard program
- * Small / ergonomic:
52 mm system for *credit cards and tickets*
- * Speeds exceed 200 ft/min
- * Easy roll change
- * Cost competitive
- * Engineered in Switzerland

System sizes	System width B	Foil width F
System 1:	52 mm	12-30 mm
System 2:	75 mm	25-50 mm
System 3:	100 mm	25-75 mm
System 4:	150 mm	25-125 mm
System 5:	customer specific	

For more Information:
 I.KELA Company
 4405 Independence Court
 Sarasota, FL 34234
 T: 941-355-6498
 F: 941-355-1391
 Email: sales@ikela.com

